

**JUMO GmbH & Co. KG**  
Delivery address: Mackenrodtstraße 14  
36039 Fulda, Germany  
Postal address: 36035 Fulda, Germany  
Phone: +49 661 6003-0  
Fax: +49 661 6003-607  
E-mail: mail@jumo.net  
Internet: www.jumo.net

**JUMO Instrument Co. Ltd.**  
JUMO House  
Temple Bank, Riverway  
Harlow, Essex CM20 2DY, UK  
Phone: +44 1279 635533  
Fax: +44 1279 635262  
E-mail: sales@jumo.co.uk  
Internet: www.jumo.co.uk

**JUMO Process Control, Inc.**  
8 Technology Boulevard  
Canastota, NY 13032, USA  
Phone: 315-697-5866  
1-800-554-JUMO  
Fax: 315-697-5867  
E-mail: info@jumo.us  
Internet: www.jumo.us



# JUMO Dtrans T100 Screw-in RTD temperature probe with/without transmitter

- for temperatures from -50 to +260 °C
- EHEDG certification
- complies with ROHS for EU and China
- configuration by setup program via USB interface
- M12 × 1 plug connection; IP67 protection according to EN 60529 with machine connector plugged in
- Product with an integrated transmitter is not intended for export to the USA!

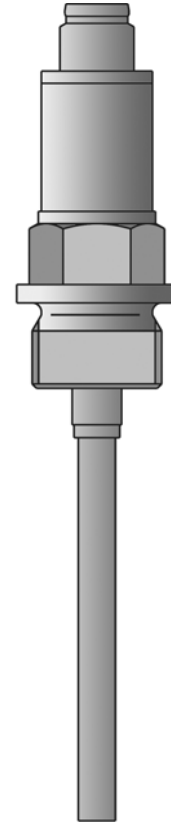

The screw-in RTD temperature probe, which has a compact design, consists of a sheath with an integrated temperature sensor, a process connection, and an attached housing for the transmitter electronics. The built-in programmable 2-wire transmitter converts the resistance value into a current signal.

The screw-in RTD temperature probe and the programmable 2-wire transmitter are used for measuring temperatures from -50 to +150 °C (-58 to +302 °F) or to 260 °C (500 °F) with an extension piece (without the transmitter: -50 to +200 °C or -58 to +392 °F).

The range, fine calibration or measuring circuit monitoring etc. can all be configured with the help of a setup program.

The 4 to 20 mA or (reversed) 20 to 4 mA output signal that is provided is linear with temperature. The instrument is designed for industrial applications and complies with the European standards for assuring electromagnetic compatibility (EMC).

**The transmitter must be protected from temperatures above 85 °C !**

## Technical data

### Electrical connection

machine connector M12 × 1, 4-pole according to IEC 60947-5-2; FIXCON-capable

### Process connection

G 3/8 (3/8" pipe) thread  
G 1/2 (1/2" pipe) thread  
G 1/2 (1/2" pipe) thread with CIP-compliant conical seal, with EHEDG certification  
taper nipple with cap nut (milk pipe screw fitting)  
clamping nipple according to DIN 32676  
ball weld-in socket with clamping thread  
weld-in socket with CIP-compliant conical seal  
Varivent connections with EHEDG certification  
ball weld-in socket  
JUMO PEKA with EHEDG certification

### Sheath

stainless steel 316 L (Mat. Ref. 1.4404/1.4435);  
stainless steel 316 Ti (Mat. Ref. 1.4571) (on request)

### Protection type

IP67 protection according to EN 60529, with the machine connector plugged in

### Response time

water 0.4 m/s sheath standard  $t_{0.5} = 5$  s;  $t_{0.9} = 12$  s  
water 0.4 m/s sheath stepped  $t_{0.5} = 2$  s;  $t_{0.9} = 5$  s  
air 3.0 m/s sheath standard  $t_{0.5} = 40$  s;  $t_{0.9} = 110$  s  
air 3.0 m/s sheath stepped  $t_{0.5} = 21$  s;  $t_{0.9} = 70$  s

### Measuring insert

**without transmitter:**  
Pt100 or Pt1000 temperature sensor, EN 60751, Class A, B or AA (1/3 Class B),  
2- or 4-wire circuit  
**with programmable transmitter:**  
Pt1000 temperature sensor, EN 60751, Class A,  
4-wire circuit

**JUMO GmbH & Co. KG**  
 Delivery address: Mackenrodtstraße 14  
 36039 Fulda, Germany  
 Postal address: 36035 Fulda, Germany  
 Phone: +49 661 6003-0  
 Fax: +49 661 6003-607  
 E-mail: mail@jumo.net  
 Internet: www.jumo.net

**JUMO Instrument Co. Ltd.**  
 JUMO House  
 Temple Bank, Riverway  
 Harlow, Essex CM20 2DY, UK  
 Phone: +44 1279 635533  
 Fax: +44 1279 635262  
 E-mail: sales@jumo.co.uk  
 Internet: www.jumo.co.uk

**JUMO Process Control, Inc.**  
 8 Technology Boulevard  
 Canastota, NY 13032, USA  
 Phone: 315-697-5866  
 1-800-554-JUMO  
 Fax: 315-697-5867  
 E-mail: info@jumo.us  
 Internet: www.jumo.us



## Technical data (general)

### Input

Measurement input	<b>without transmitter:</b> Pt100 or Pt1000 temperature sensor, EN 60751, Class A, B or AA (1/3 Class B), 2- or 4-wire circuit <b>with programmable transmitter:</b> Pt1000 temperature sensor, EN 60751, Class A, 4-wire circuit
Measuring ranges	Basic type 902815/10... : -50 to +200 °C Basic type 902815/20... : -50 to +150 °C Basic type 902815/21... : -50 to +260 °C with extension
Tolerance limits	0.15 + 0.002 ×  t  <sup>1</sup> , Class A (standard) 0.10 + 0.0017 ×  t  <sup>1</sup> , Class AA (1/3 Class B) 0.30 + 0.005 ×  t  <sup>1</sup> , Class B

### Environmental influences

Ambient temperature range for the head	Basic type 902815/10... : -30 to +90 °C Basic types 902815/20... and 902815/21... : -30 to +85 °C
Storage temperature range	-30 to +90 °C
Climatic conditions	according to IEC 68-2-30 (rel. humidity ≤ 95 % with condensation)
Vibration strength	according to IEC 68-2-6 (according to GL characteristic)

## Technical data (transmitter)

### Input

Shortest span	10 K
Sampling rate	1 measurement per second
Input filter	1st order digital filter; filter constant adjustable from 0 to 125 s

### Measuring circuit monitoring

Underrange	linear fall off to 3.8 mA (according to NAMUR recommendation 43)
Overrange	linear rise up to 20.5 mA (according to NAMUR recommendation 43)
Probe short-circuit, probe or lead break	≤ 3.6 mA or ≥ 21.0 mA (configurable)
Current limiting for probe short-circuit or probe break	≤ 25 mA

### Output

Output signal	proportional DC current 4 to 20 mA or 20 to 4 mA
Transfer characteristic	linear with temperature
Maximum burden resistance (R <sub>B</sub> )	R <sub>B</sub> = (U <sub>b</sub> - 8 V) / 23 mA, max. 600 Ω
Burden error	≤ ±0.02 %/100 Ω <sup>2</sup>
Settling time after temperature change	≤ 5 s
Settling time after switch-on or reset	≤ 5 s
Measuring accuracy for electronics	0.1 °C or 0.08 % <sup>3</sup>

### Electrical data

Voltage supply (U <sub>b</sub> )	8 to 35 V DC (pin 1 = +, pin 3 = -), only for operation in SELV or PELV circuits according to EN 50178
Reverse polarity protection	yes
Voltage supply error	≤ ± 0.01 % per V deviation from 24 V <sup>2</sup>

### Environmental influences

Ambient temperature error	≤ ±(15 ppm/°C × (range end + 200) + 50 ppm/°C × set range) × Δv Δv = deviation of ambient temperature from the reference temperature
Calibration/reference conditions	24 V DC at 25 °C ± 5 °C (77 °F ± 9 °F)
Electromagnetic compatibility (EMC)	EN 61326
- interference emission	Class B
- interference immunity	industrial requirements

<sup>1</sup> |t| is the numerical value of the temperature in °C, disregarding the sign.

<sup>2</sup> % details refer to the end of range value 20 mA.

<sup>3</sup> % details refer to the measuring span that has been set, the larger value applies.

**JUMO GmbH & Co. KG**  
 Delivery address: Mackenrodtstraße 14  
 36039 Fulda, Germany  
 Postal address: 36035 Fulda, Germany  
 Phone: +49 661 6003-0  
 Fax: +49 661 6003-607  
 E-mail: mail@jumo.net  
 Internet: www.jumo.net

**JUMO Instrument Co. Ltd.**  
 JUMO House  
 Temple Bank, Riverway  
 Harlow, Essex CM20 2DY, UK  
 Phone: +44 1279 635533  
 Fax: +44 1279 635262  
 E-mail: sales@jumo.co.uk  
 Internet: www.jumo.co.uk

**JUMO Process Control, Inc.**  
 8 Technology Boulevard  
 Canastota, NY 13032, USA  
 Phone: 315-697-5866  
 1-800-554-JUMO  
 Fax: 315-697-5867  
 E-mail: info@jumo.us  
 Internet: www.jumo.us



### Connection example with transmitter

Connection example with power supply unit

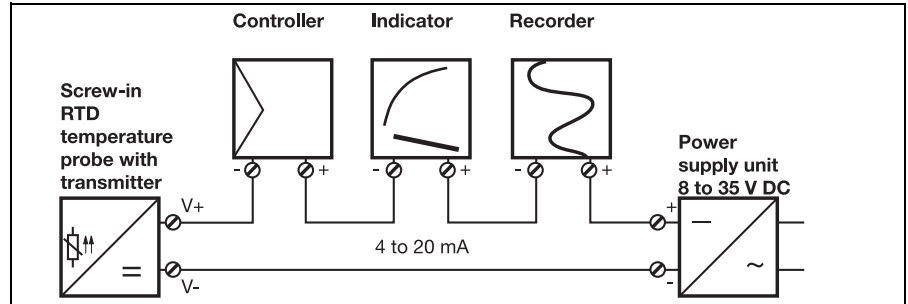

### Connection example with supply isolator

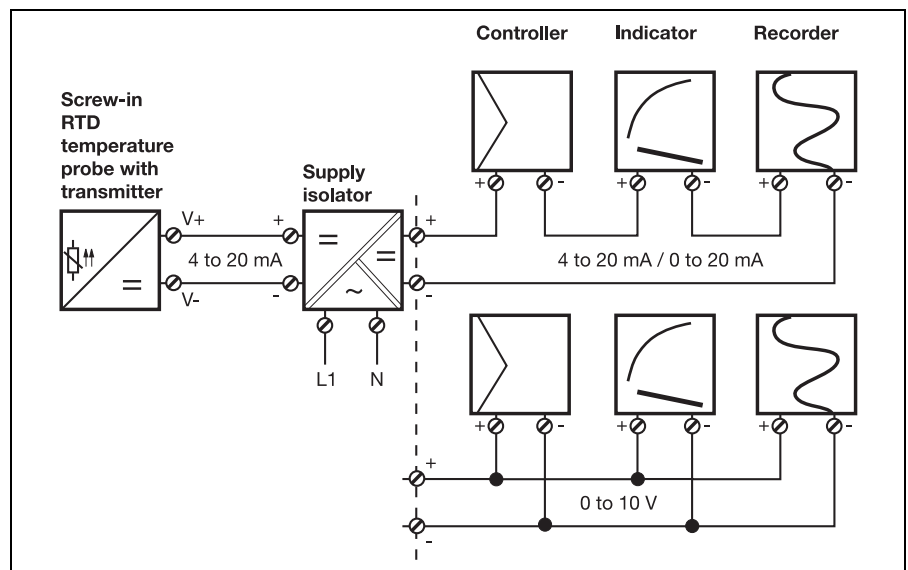

### Connection diagram

Machine connector M12 x 1, 4-pole according to IEC 60947-5-2

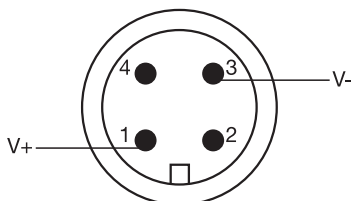
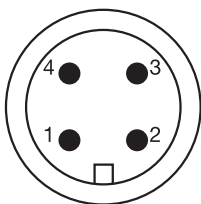

**Caution:**  
do not make any connection to pins 2 and 4!

Electrical connection		Terminal assignments
<b>Basic type 902815/10... without transmitter</b>		
Screw-in RTD temperature probe in 2-wire circuit		
Screw-in RTD temperature probe in 4-wire circuit		
<b>Basic type 902815/20... and 902815/21... with programmable transmitter</b>		
Voltage supply 8 to 35 V DC		
Current output 4 to 20 mA		
Setup communication via special configuration cable (only for configuration – not for continuous operation)		

**JUMO GmbH & Co. KG**  
 Delivery address: Mackenrodtstraße 14  
 36039 Fulda, Germany  
 Postal address: 36035 Fulda, Germany  
 Phone: +49 661 6003-0  
 Fax: +49 661 6003-607  
 E-mail: mail@jumo.net  
 Internet: www.jumo.net

**JUMO Instrument Co. Ltd.**  
 JUMO House  
 Temple Bank, Riverway  
 Harlow, Essex CM20 2DY, UK  
 Phone: +44 1279 635533  
 Fax: +44 1279 635262  
 E-mail: sales@jumo.co.uk  
 Internet: www.jumo.co.uk

**JUMO Process Control, Inc.**  
 8 Technology Boulevard  
 Canastota, NY 13032, USA  
 Phone: 315-697-5866  
 1-800-554-JUMO  
 Fax: 315-697-5867  
 E-mail: info@jumo.us  
 Internet: www.jumo.us



**Dimensions – basic types**

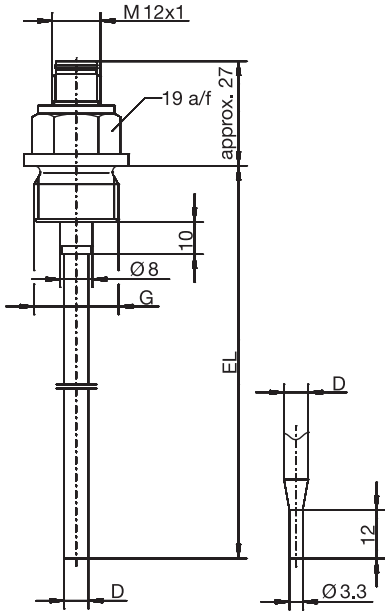

Basic type 902815/10...  
without transmitter

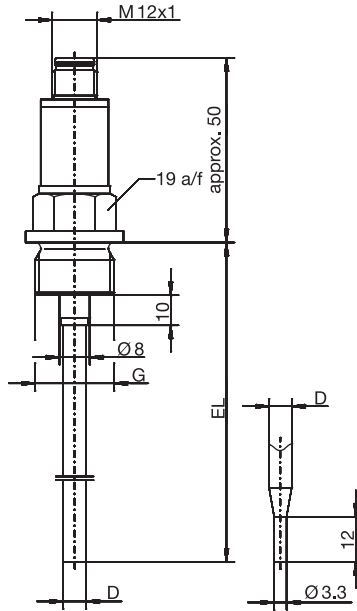

Basic type 902815/20...  
with transmitter

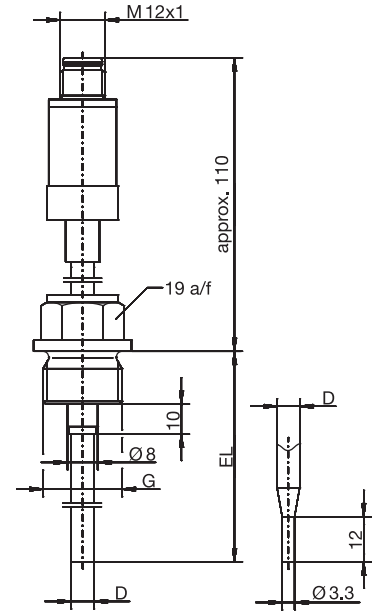

Basic type 902815/21...  
with transmitter and extension

**Dimensions of process connections (PA)**

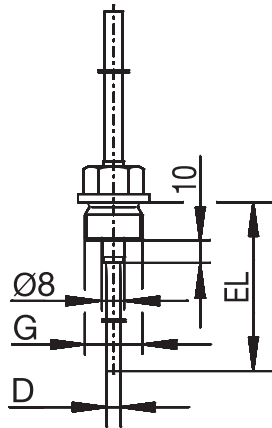

PA	G
103	3/8
104	1/2

Screw fitting

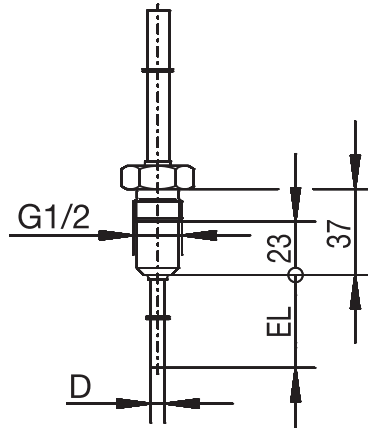

PA	
380	

Screw fitting  
with CIP-compliant conical seal

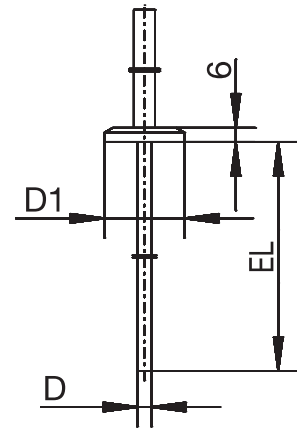

PA	DN	D1	PA	DN	D1
-	-	Ø 25	613	40/1.5"	Ø 50.5
611	10/20	Ø 34	616	50/2"	Ø 64
613	25/1"	Ø 50.5	617	2.5"	Ø 77.5

Clamping nipple according to DIN 32676  
(clamp)

**JUMO GmbH & Co. KG**  
 Delivery address: Mackenrodtstraße 14  
 36039 Fulda, Germany  
 Postal address: 36035 Fulda, Germany  
 Phone: +49 661 6003-0  
 Fax: +49 661 6003-607  
 E-mail: mail@jumo.net  
 Internet: www.jumo.net

**JUMO Instrument Co. Ltd.**  
 JUMO House  
 Temple Bank, Riverway  
 Harlow, Essex CM20 2DY, UK  
 Phone: +44 1279 635533  
 Fax: +44 1279 635262  
 E-mail: sales@jumo.co.uk  
 Internet: www.jumo.co.uk

**JUMO Process Control, Inc.**  
 8 Technology Boulevard  
 Canastota, NY 13032, USA  
 Phone: 315-697-5866  
 1-800-554-JUMO  
 Fax: 315-697-5867  
 E-mail: info@jumo.us  
 Internet: www.jumo.us



**Dimensions of process connections (PA)**

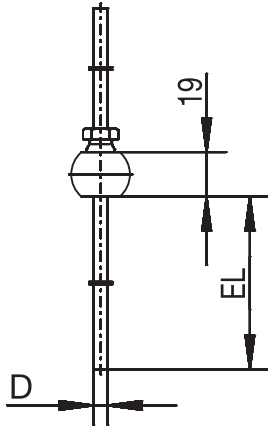

PA	DN	D1
681		

**Ball weld-in socket with clamping thread**

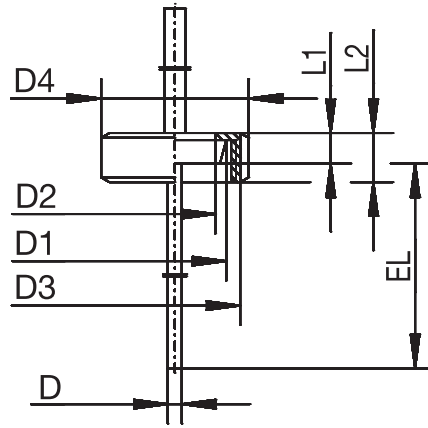

PA	DN	D1	D2	D3	D4	L1	L2
601	10	Ø 22	Ø 18	RD 28x1/8	Ø 38	9	18
604	25	Ø 44	Ø 35	RD 52x1/6	Ø 63	13	21
605	32	Ø 50	Ø 41	RD 58x1/6	Ø 70	13	21

**Taper nipple with cap nut according to DIN 11851 (milk pipe screw fitting)**

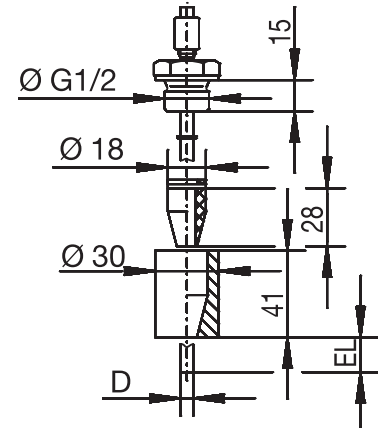

PA	DN	D1
682		

**Weld-in socket with CIP-compliant conical seal**

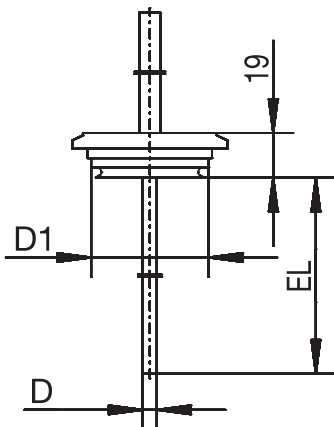

PA	DN	D1
684	15/10	Ø 31
685	32/25	Ø 50
686	50/40	Ø 68

**Varivent connection**

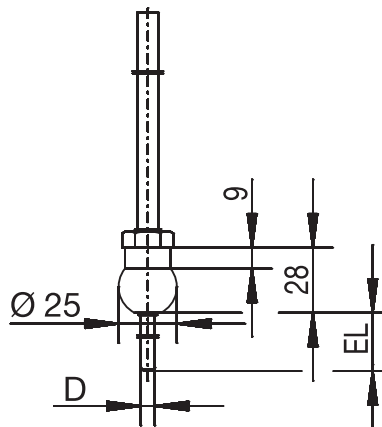

PA	DN	D1
681		

**Ball weld-in socket**

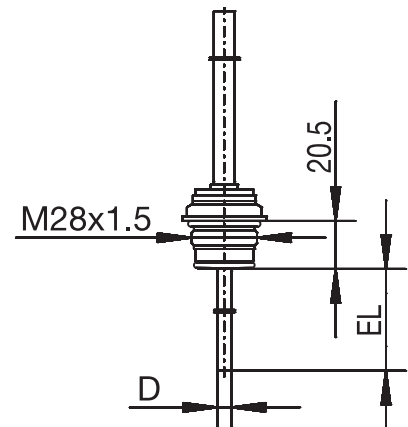

Varivent	Clamp	Aseptic	Weld-in socket
DN 25/32	DN 25/32/40	DN 40	Ø 55 mm
DN 40-125	DN 50	DN 50	-
-	-	NKS DN 40	-

**JUMO PEKA PA 997 Process connection adapter, see data sheet 409711**

**JUMO GmbH & Co. KG**  
 Delivery address: Mackenrodtstraße 14  
 36039 Fulda, Germany  
 Postal address: 36035 Fulda, Germany  
 Phone: +49 661 6003-0  
 Fax: +49 661 6003-607  
 E-mail: mail@jumo.net  
 Internet: www.jumo.net

**JUMO Instrument Co. Ltd.**  
 JUMO House  
 Temple Bank, Riverway  
 Harlow, Essex CM20 2DY, UK  
 Phone: +44 1279 635533  
 Fax: +44 1279 635262  
 E-mail: sales@jumo.co.uk  
 Internet: www.jumo.co.uk

**JUMO Process Control, Inc.**  
 8 Technology Boulevard  
 Canastota, NY 13032, USA  
 Phone: 315-697-5866  
 1-800-554-JUMO  
 Fax: 315-697-5867  
 E-mail: info@jumo.us  
 Internet: www.jumo.us



**Order details: JUMO Dtrans T100 Screw-in RTD temperature probe with/without transmitter**  
**- Product with an integrated transmitter is not intended for export to the USA! -**

		<b>(1) Basic type</b>	
	902815/10	Screw-in RTD temperature probe without transmitter, connection: M12 × 1 machine connector, parts in contact with the medium: electrolytically polished; surface roughness Ra ≤ 0.8 µm	
	902815/20	Screw-in RTD temperature probe with programmable transmitter <sup>2</sup> , connection: M12 × 1 machine connector, parts in contact with the medium: electrolytically polished; surface roughness Ra ≤ 0.8 µm	
	902815/21	Screw-in RTD temperature probe with programmable transmitter <sup>2</sup> , high-temperature version with extension, parts in contact with the medium: electrolytically polished; surface roughness Ra ≤ 0.8 µm	
		<b>(2) Operating temperature in °C</b>	
x	370	-50 to +150 °C (max. transmitter temperature 85 °C)	
x	380	-50 to +200 °C	
x	386	-50 to +260 °C (max. transmitter temperature 85 °C)	
		<b>(3) Measuring insert</b>	
x	1003	1 × Pt100 in 2-wire circuit	
x	1005	1 × Pt1000 in 2-wire circuit	
x	1011	1 × Pt100 in 4-wire circuit	
x x x	1013	1 × Pt1000 in 4-wire circuit	
		<b>(4) Tolerance class according to EN 60751</b>	
x	1	Class B (standard at basic type 902815/10...)	
x x x	2	Class A (standard at basic type 902815/2....)	
x	3	Class AA (1/3 Class B)	
		<b>(5) Sheath diameter D in mm</b>	
x x x	6	Ø 6 mm	
		<b>(6) Fitting length EL in mm (EL 50 to 500)</b>	
x x x	50	50 mm	
x x x	100	100 mm	
x x x	150	150 mm	
x x x	200	200 mm	
x x x	...	specify in plain text (50 mm steps)	
		<b>(7) Process connection (PA)</b>	
x x x	000	none (please note at basic type 902815/2.... max. transmitter temperature 85 °C)	
x x x	103	G 3/8 (3/8" pipe) thread	
x x x	104	G 1/2 (1/2" pipe) thread	
x x x	380	G 1/2 (1/2" pipe) thread with CIP-compliant conical seal, with EHEDG certification	
x x x	601	taper nipple with ring nut DN 10 according to DIN 11851 (milk pipe screw fitting)	
x x x	604	taper nipple with ring nut DN 25 according to DIN 11851 (milk pipe screw fitting)	
x x x	605	taper nipple with ring nut DN 32 according to DIN 11851 (milk pipe screw fitting)	
x x x	611	clamping nipple DN 10/20 according to DIN 32676	
x x x	613	clamping nipple DN 25/40 (1"/1.5") according to DIN 32676	
x x x	616	clamping nipple DN 50 (2") according to DIN 32676	
x x x	617	clamping nipple 2.5" similar according to DIN 32676	
x x x	681	ball weld-in socket with clamping thread	
x x x	682	weld-in socket with CIP-compliant conical seal	
x x x	684	Varivent connection DN 15/10, with EHEDG certification	
x x x	685	Varivent connection DN 32/25, with EHEDG certification	
x x x	686	Varivent connection DN 50/40, with EHEDG certification	
x x x	840	ball weld-in pocket (material 316 Ti)	
x x x	997	JUMO PEKA with EHEDG certification	
		<b>(8) Sheath material</b>	
x x x	24	stainless steel 316 L (Mat. Ref. 1.4404/1.4435)	
x x x	26	stainless steel 316 Ti (Mat. Ref. 1.4571) (on request)	
		<b>(9) Extra codes</b>	
x x x	000	none	
x x x	100	customer-specific factory setting (please specify parameters in plain text)	
x x x	310	sheath stepped down from Ø 6 mm dia. to Ø 3.3 mm	
x x x	810	weld-in socket (only for process connection 380)	

**Order code**                    (1)        (2)        (3)        (4)        (5)        (6)        (7)        (8)        (9)        /        ...<sup>1</sup>  
**Order example**                902815/20 - 370 - 1013 - 2 - 6 - 100 - 104 - 24 / 000

<sup>1</sup> List extra codes in sequence, separated by commas.  
<sup>2</sup> Specify measuring range in plain text.

**JUMO GmbH & Co. KG**  
 Delivery address: Mackenrodtstraße 14  
 36039 Fulda, Germany  
 Postal address: 36035 Fulda, Germany  
 Phone: +49 661 6003-0  
 Fax: +49 661 6003-607  
 E-mail: mail@jumo.net  
 Internet: www.jumo.net

**JUMO Instrument Co. Ltd.**  
 JUMO House  
 Temple Bank, Riverway  
 Harlow, Essex CM20 2DY, UK  
 Phone: +44 1279 635533  
 Fax: +44 1279 635262  
 E-mail: sales@jumo.co.uk  
 Internet: www.jumo.co.uk

**JUMO Process Control, Inc.**  
 8 Technology Boulevard  
 Canastota, NY 13032, USA  
 Phone: 315-697-5866  
 1-800-554-JUMO  
 Fax: 315-697-5867  
 E-mail: info@jumo.us  
 Internet: www.jumo.us



## Setup program

The setup program is used for configuring the programmable 2-wire transmitter with the aid of a PC.

This requires:

- configuration cable with plug connector, socket and Western plug
- PVC connecting cable, length 2 meters
- PC interface with USB/TTL converter and USB cable

(see accessories for programmable 2-wire transmitter)

In order to configure the 2-wire transmitter, it has to be connected to a voltage supply. If no power supply or supply isolator is available, it can also be configured by using a 9 V battery as a power source.

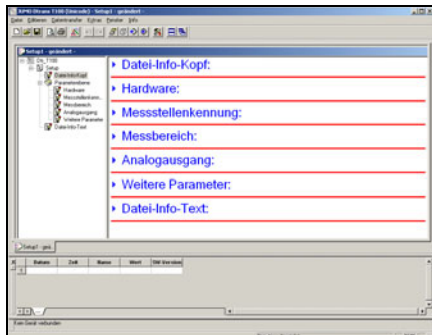

## Configurable parameters

### Measuring point ID

- TAG number

### Range configurable in °C/°F

- Offset
- Range start
- Range end

### Analog output

- Reversed output
- Signal for probe break/short-circuit

### Additional parameters

- Filter time constant
- Unit

## Hardware and software requirements

The following hardware and software requirements have to be met for installing and operating the software:

### Minimum configuration

- Intel Pentium<sup>1</sup> III
- Microsoft Windows<sup>2</sup> 2000 or XP
- 256 MB main memory
- CD-ROM drive
- mouse
- free USB interface
- 120 MB available on hard disk

### Recommended configuration

- Intel Pentium 4
- Windows XP
- 512 MB main memory

### Notes for Windows 2000 or XP

If more than one user is administered by the computer, then the user who is logged in must be the one who will subsequently be working with the program.

The user must have administrator rights during the installation of the software. After installation, the rights can be restricted again. If this is disregarded, it is not possible to ensure a correct and complete installation.

## Standard accessories

1 Operating Instructions B 902815.0

## Accessories for programmable 2-wire transmitter

Setup program on CD-ROM, multilingual

Configuration cable, 4-pole with plug and socket M12 × 1 and Western connector RJ-45

PVC connecting cable, 4-pole with M12 × 1 socket, length 2000 mm

PC interface with USB/TTL converter and USB cable

Power supply units: 1- way and 4-way (data sheet 707500)

Isolating amplifier and supply isolator for electrical isolation of standard signals and voltage supply for 2-wire transmitter (data sheet 707510)

### Part No.

90/00485016  
 90/00484692  
 90/00404585  
 70/00456352  
 -  
 -

## Stock versions

(1)	(2)	(3)	(4)	(5)	(6)	(7)	(8)	(9)	Part No.
902815/10	- 380	- 1011	- 1	- 6	- 100	- 104	- 24	/ 000	90/00508463
902815/10	- 380	- 1011	- 3	- 6	- 50	- 104	- 24	/ 000	90/00516241
902815/10	- 380	- 1011	- 3	- 6	- 150	- 104	- 24	/ 000	90/00516245
902815/10	- 380	- 1011	- 3	- 6	- 200	- 104	- 24	/ 000	90/00516246
902815/20	- 370	- 1013	- 2	- 6	- 50	- 104	- 24	/ 000	90/00508279
902815/20	- 370	- 1013	- 2	- 6	- 100	- 380	- 24	/ 000	90/00513650
902815/20	- 370	- 1013	- 2	- 6	- 100	- 104	- 24	/ 000	90/00491506
902815/20	- 370	- 1013	- 2	- 6	- 150	- 000	- 24	/ 000	90/00506630
902815/20	- 370	- 1013	- 2	- 6	- 200	- 104	- 24	/ 000	90/00503113

<sup>1</sup> Intel and Pentium are registered trademarks of Intel Corporation.

<sup>2</sup> Microsoft and Windows are registered trademarks of Microsoft Corporation.